

Mathematics!



"A Story of Units"

Parent Handbook

Grade 5
Module 5

Addition and Multiplication with Volume and Area

OVERVIEW

In this 25-day module, students work with two- and three-dimensional figures. Volume is introduced to students through concrete exploration of cubic units and culminates with the development of the volume formula for right rectangular prisms. The second half of the module turns to extending students' understanding of two-dimensional figures. Students combine prior knowledge of area with newly acquired knowledge of fraction multiplication to determine the area of rectangular figures with fractional side lengths. They then engage in hands-on construction of two-dimensional shapes, developing a foundation for classifying the shapes by reasoning about their attributes. This module fills a gap between Grade 4's work with two-dimensional figures and Grade 6's work with volume and area.

In Topic A, students extend their spatial structuring to three dimensions through an exploration of volume. Students come to see volume as an attribute of solid figures and understand that cubic units are used to measure it. Using improvised, customary, and metric units, they build three-dimensional shapes, including right rectangular prisms, and count units to find the volume. By developing a systematic approach to counting the unit cubes, students make connections between area and volume. They partition a rectangular prism into layers of unit cubes and reason that the number of unit cubes in a single layer corresponds to the number of unit squares on a face. They begin to conceptualize the layers themselves, oriented in any one of three directions, as iterated units. This understanding allows students to reason about containers formed by nets, reasonably predict the number of cubes required to fill them, and test their prediction by packing the container.

Concrete understanding of volume and multiplicative reasoning come together in Topic B as the systematic counting from Topic A leads naturally to formulas for finding the volume of a right rectangular prism. Students solidify the connection between volume as *packing* and volume as *filling* by comparing the amount of liquid that fills a container to the number of cubes that can be packed into it. This connection is formalized as students see that 1 cubic centimeter is equal to 1 milliliter. Complexity increases as students use their knowledge that volume is additive to partition and calculate the total volume of solid figures composed of non-overlapping, rectangular prisms. Word problems involving the volume of rectangular prisms with whole number edge lengths solidify understanding and give students opportunity to reason about scaling in the context of volume. This topic concludes with a design project that gives students the opportunity to apply the concepts and formulas they have learned throughout Topics A and B to create a sculpture of a specified volume composed of varied rectangular prisms with parameters given in the project description.

In Topic C, students extend their understanding of area as they use rulers and set squares to construct and measure rectangles with fractional side lengths and find their areas. They apply their extensive knowledge of fraction multiplication to interpret areas of rectangles with fractional side lengths and solve real world problems involving these figures, including reasoning about scaling through contexts in which volumes are compared. Visual models and equations are used to represent the problems through the Read-Draw-Write protocol.

In Topic D, students draw two-dimensional shapes in order to analyze their attributes and use those attributes to classify them. Familiar figures, such as parallelograms, rhombuses, squares, trapezoids, etc., have all been defined in earlier grades, and by Grade 4 students have gained an understanding of shapes beyond the intuitive level. Grade 5 extends this understanding through an in-depth analysis of the properties and defining attributes of quadrilaterals. Grade 4's work with the protractor is applied in order to construct various quadrilaterals. Using measurement tools illuminates the attributes used to define and recognize each quadrilateral. Students see, for example, that the same process that they used to construct a parallelogram will also produce a rectangle when all angles are constructed to measure 90 degrees. Students then analyze defining attributes and create a hierarchical classification of quadrilaterals.

**The sample questions/responses contained in this manual are straight from <http://www.engageny.org/>. They are provided to give some insight into the kinds of skills expected of students as each lesson is taught.

Terminology

New or Recently Introduced Terms

- Base (one face of a three-dimensional solid—often thought of as the surface upon which the solid rests)
- Bisect (divide into two equal parts)
- Cubic units (cubes of the same size used for measuring)
- Height (adjacent layers of the base that form a rectangular prism)
- Hierarchy (series of ordered groupings of shapes)
- Unit cube (cube whose sides all measure 1 unit; cubes of the same size used for measuring volume)
- Volume of a solid (measurement of space or capacity)

Familiar Terms and Symbols

- Angle (the union of two different rays sharing a common vertex)
- Area (the number of square units that covers a two-dimensional shape)
- Attribute (given quality or characteristic)
- Cube (three-dimensional figure with six square sides)
- Degree measure of an angle (subdivide the length around a circle into 360 arcs of equal length; a central angle for any of these arcs is called a *one-degree angle* and is said to have angle measure 1 degree)
- Face (any flat surface of a three-dimensional figure)
- Kite (quadrilateral with two equal sides that are also adjacent; a kite can be a rhombus if all sides are equal)
- Parallel lines (two lines in a plane that do not intersect)
- Parallelogram (four-sided closed figure with opposite sides that are parallel)
- Perpendicular (two lines are *perpendicular* if they intersect, and any of the angles formed between the lines are 90° angles)
- Perpendicular bisector (line that cuts a line segment into two equal parts at 90°)
- Plane (flat surface that extends infinitely in all directions)
- Polygon (closed figure made up of line segments)
- Quadrilateral (closed figure with four sides)
- Rectangle (quadrilateral with four 90° angles)
- Rectangular prism (three-dimensional figure with six rectangular sides)
- Rhombus (parallelogram with equal sides)
- Right angle (angle formed by perpendicular lines; angle measuring 90°)
- Right rectangular prism (rectangular prism with only 90° angles)
- Solid figure (three-dimensional figure)
- Square units (squares of the same size, used for measuring)
- Three-dimensional figures (solid figures)
- Trapezoid (quadrilateral with at least one pair of parallel sides)
- Two-dimensional figures (figures on a plane)

Suggested Tools and Representations

- Ruler
- Protractor
- Set square

Lesson 1

Objective: Explore volume by building with and counting unit cubes.

Build 2 different structures with the following volumes using your cubic units. Then draw one of the figures on the dot paper. One example has been drawn for you.

a. 4 cubic units

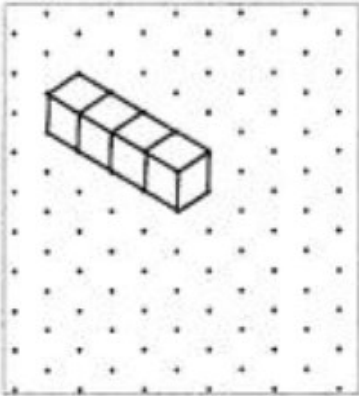

b. 7 cubic units

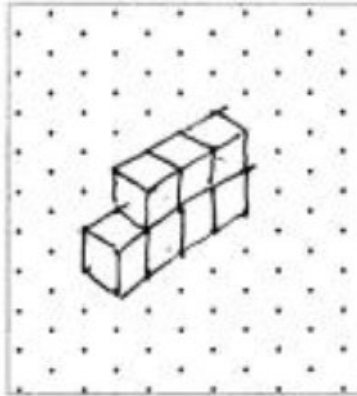

c. 8 cubic units

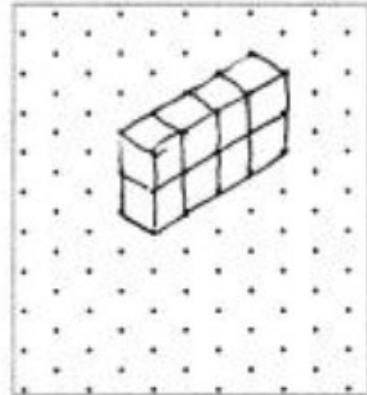

Lesson 2

Objective: Find the volume of a right rectangular prism by packing with cubic units and counting.

Shade the following figures on centimeter grid paper. Cut and fold each to make 3 open boxes, taping them so they hold their shapes. Pack each box with cubes. Write how many cubes fill the box.

a.

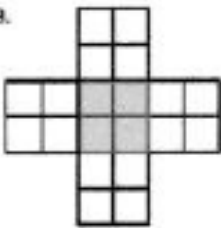

Number of cubes: 8

b.

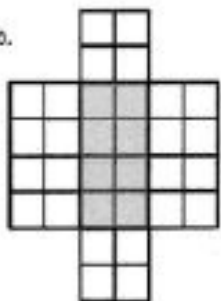

Number of cubes: 16

Lesson 3

Objective: Compose and decompose right rectangular prisms using layers.

Use the prisms to find the volume.

- Build the rectangular prism pictured to the left with your cubes, if necessary.
- Decompose it into layers in 3 different ways and show your thinking on the blank prisms.
- Complete the missing information in the table.

a.



Number of Layers	Number of Cubes in Each Layer	Volume of the Prism
2	12	24 cubic cm
6	4	24 cubic cm
2	12	24 cubic cm

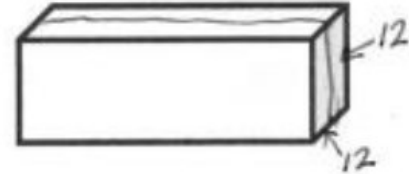
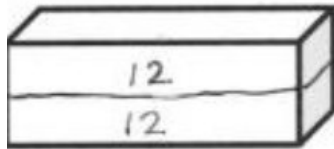

Lesson 4

Objective: Use multiplication to calculate volume.

Each rectangular prism is built from centimeter cubes. State the dimensions and find the volume.

a.



Length: 5 cm

Width: 2 cm

Height: 2 cm

Volume: 20 cm³

$$5 \times 2 \times 2$$

$$\underline{10} \times 2 = 20$$

Calculate the volume of each rectangular prism. Include the units in your number sentences.

a.

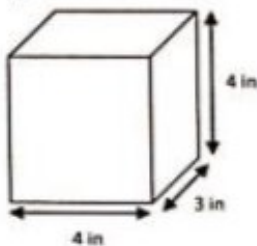

$$V = 4 \text{ in} \times 3 \text{ in} \times 4 \text{ in} = 48 \text{ in}^3$$

b.

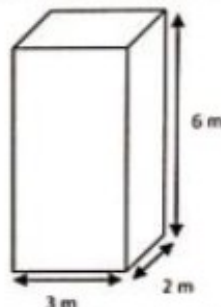

$$V = 3 \text{ m} \times 2 \text{ m} \times 6 \text{ m} = 36 \text{ m}^3$$

Lesson 5—Objective: Use multiplication to connect volume as “packing” with volume as “filling”.

The tank, shaped like a rectangular prism, is filled to the top with water.

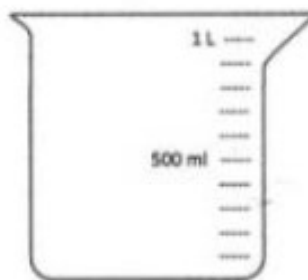
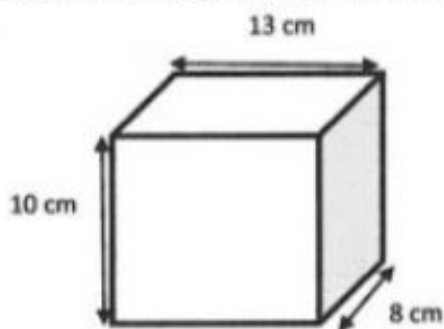

$$1 \text{ L} = 1000 \text{ mL}$$

Will the beaker hold all the water in the box? If yes, how much more will the beaker hold? If not, how much more will the cube hold than the beaker? Explain how you know.

$V = 10 \text{ cm} \times 8 \text{ cm} \times 13 \text{ cm} = 1,040 \text{ cm}^3$ No, the beaker holds 40 mL less than the cube. $1 \text{ L} = 1,000 \text{ mL}$, and $1,040 \text{ cm}^3 = 1,040 \text{ mL}$. $1,040 \text{ mL}$ is 40 more than $1,000 \text{ mL}$.

Lesson 6

Objective: Find the total volume of solid figures composed of two non-overlapping rectangular prisms.

Find the total volume of the figures and record your solution strategy.

a.

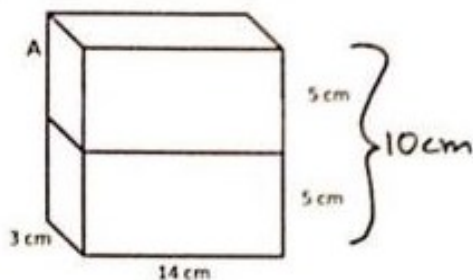

$$\text{Volume: } V = 14 \text{ cm} \times 3 \text{ cm} \times 10 \text{ cm} = 420 \text{ cm}^3$$

Solution Strategy:

I combined the 2 heights to get 10 cm. Then I just used the formula for V .

b.

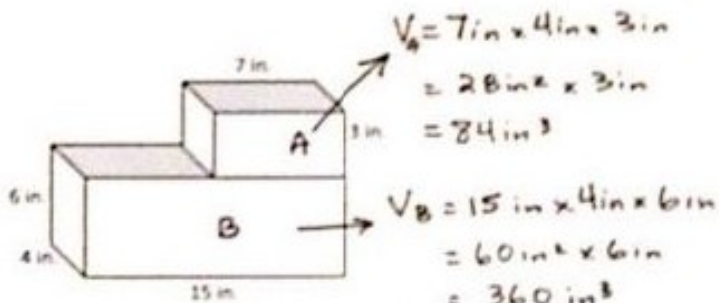

$$\begin{aligned} V_A &= 7 \text{ in} \times 4 \text{ in} \times 3 \text{ in} \\ &= 28 \text{ in}^2 \times 3 \text{ in} \\ &= 84 \text{ in}^3 \end{aligned}$$

$$\begin{aligned} V_B &= 15 \text{ in} \times 4 \text{ in} \times 6 \text{ in} \\ &= 60 \text{ in}^2 \times 6 \text{ in} \\ &= 360 \text{ in}^3 \end{aligned}$$

$$\text{Volume: } 360 \text{ in}^3 + 84 \text{ in}^3 = 444 \text{ in}^3$$

Solution Strategy:

Prism A & B have the same width, so I used the V formula & then added the 2 volumes to find the total.

Lesson 7—Objective: Solve word problems involving the volume of rectangular prisms with whole number edge lengths.

Geoffrey wants to grow some tomatoes in four large planters. He wants each planter to have a volume of 320 cubic feet, but he wants them all to be different. Show four different ways Geoffrey can make these planters, and draw diagrams with the planters' measurements on them.

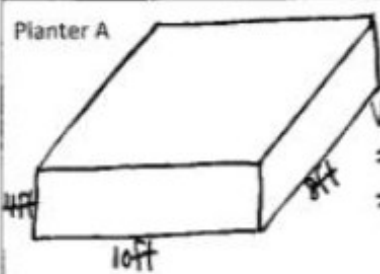
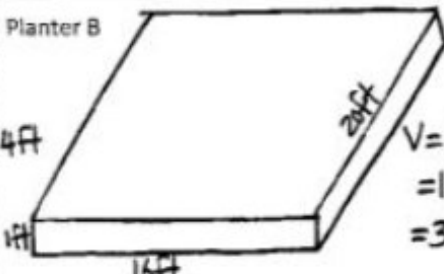
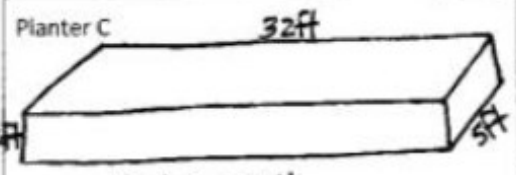
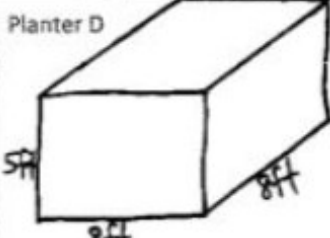
<p>Planter A</p>  <p>$V = L \times W \times H$ $= 10\text{ft} \times 8\text{ft} \times 4\text{ft}$ $= 320\text{ft}^3$</p>	<p>Planter B</p>  <p>$V = L \times W \times H$ $= 16\text{ft} \times 20\text{ft} \times 1\text{ft}$ $= 320\text{ft}^3$</p>
<p>Planter C</p>  <p>$V = L \times W \times H$ $= 32\text{ft} \times 5\text{ft} \times 2\text{ft}$ $= 320\text{ft}^3$</p>	<p>Planter D</p>  <p>$V = L \times W \times H$ $= 8\text{ft} \times 8\text{ft} \times 5\text{ft}$ $= 320\text{ft}^3$</p>

Lesson 8

Objective: Apply concepts and formulas of volume to design a sculpture using rectangular prisms within given parameters.

My sculpture has 5 to 7 rectangular prisms.		Number of prisms: <u>6</u>
Each prism is labeled with a letter, dimensions, and volume.		
Prism A	<u>10</u> by <u>7</u> by <u>3</u>	Volume <u>210 cm³</u>
Prism B	<u>9</u> by <u>5</u> by <u>4</u>	Volume <u>180 cm³</u>
Prism C	<u>6</u> by <u>3</u> by <u>4</u>	Volume <u>72 cm³</u>
Prism D	<u>5</u> by <u>2</u> by <u>9</u>	Volume <u>90 cm³</u>
Prism E	<u>5</u> by <u>2</u> by <u>7</u>	Volume <u>70 cm³</u>
Prism F	<u>4</u> by <u>3</u> by <u>1</u>	Volume <u>12 cm³</u>

Lesson 9

Objective: Apply concepts and formulas of volume to design a sculpture using rectangular prisms within given parameters.

Measure the dimensions of each prism. Calculate the volume of each prism and the total volume. Record that information in the table below. If your measurements or volume differ from those listed on the project, put a star by the prism label in the table below and record on the rubric.

Prism	Dimensions	Volume
A	10 cm by 7 cm by 3 cm	210 cm ³
B	9 cm by 5 cm by 4 cm	180 cm ³
C	6 cm by 3 cm by 4 cm	72 cm ³

Lesson 10

Objective: Find the area of rectangles with whole-by-mixed and whole-by-fractional number side lengths by tiling, record by drawing, and relate to fraction multiplication.

Sketch the rectangles and your tiling. Write the dimensions and the units you counted in the blanks. Then use multiplication to confirm the area. Show your work. We will do Rectangles A and B together.

1. Rectangle A:

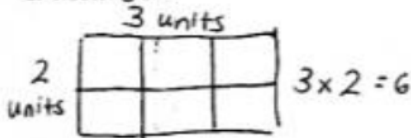

Rectangle A is

3 units long 2 units wide

Area = 6 units²

2. Rectangle B:

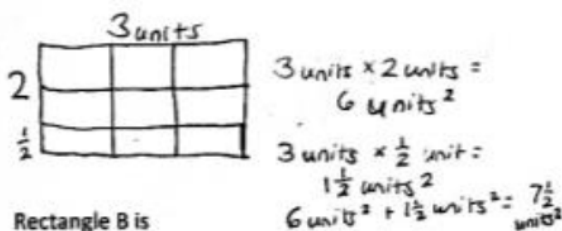

Rectangle B is

3 units long 2 1/2 units wide

Area = 7 1/2 units²

3. Rectangle C:

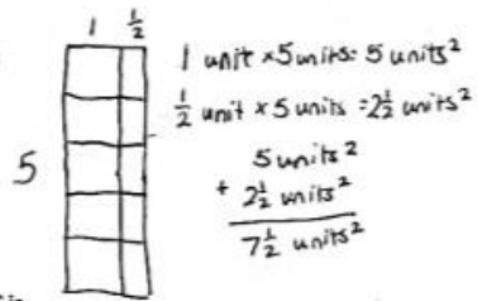

Rectangle C is

5 units long 1 1/2 units wide

Area = 7 1/2 units²

Lesson 11

Objective: Find the area of rectangles with mixed-by-mixed and fraction-by-fraction side lengths by tiling, record by drawing, and relate to fraction multiplication.

Draw the rectangle and your tiling.

Write the dimensions and the units you counted in the blanks.

Then, use multiplication to confirm the area. Show your work.

1. Rectangle A:

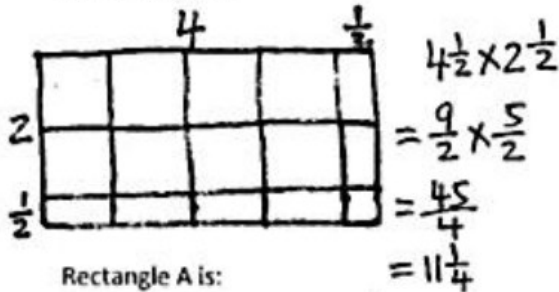

Rectangle A is:

$4\frac{1}{2}$ units long $2\frac{1}{2}$ units wide

Area = $11\frac{1}{4}$ units²

2. Rectangle B:

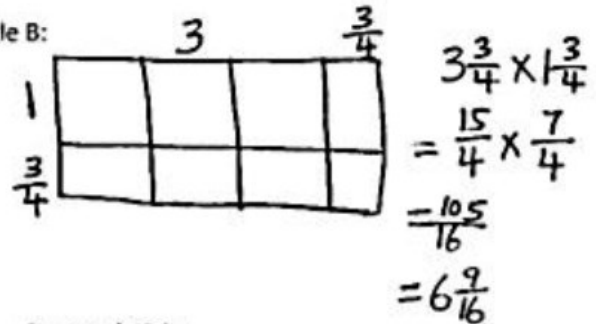

Rectangle B is:

$3\frac{3}{4}$ units long $1\frac{3}{4}$ units wide

Area = $6\frac{9}{16}$ units²

Lesson 12

Objective: Measure to find the area of rectangles with fractional side lengths.

1. Measure each rectangle with your ruler and label the dimensions. Use the area model to find each area.

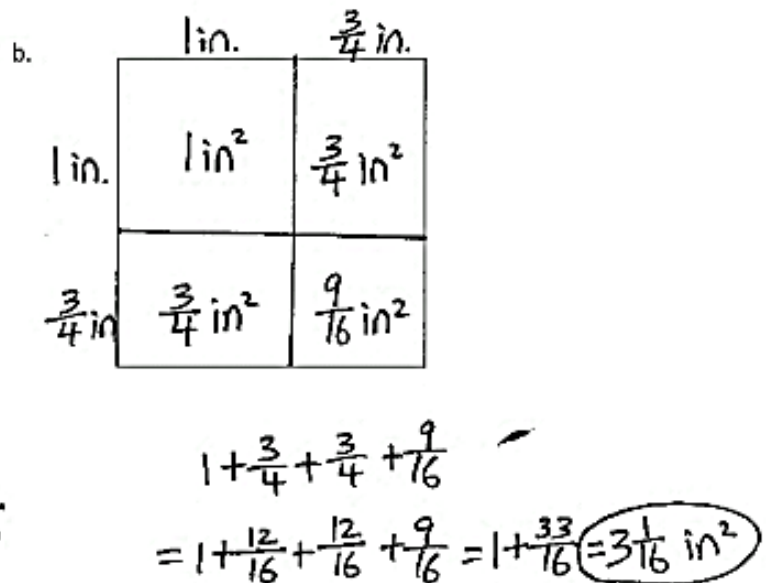
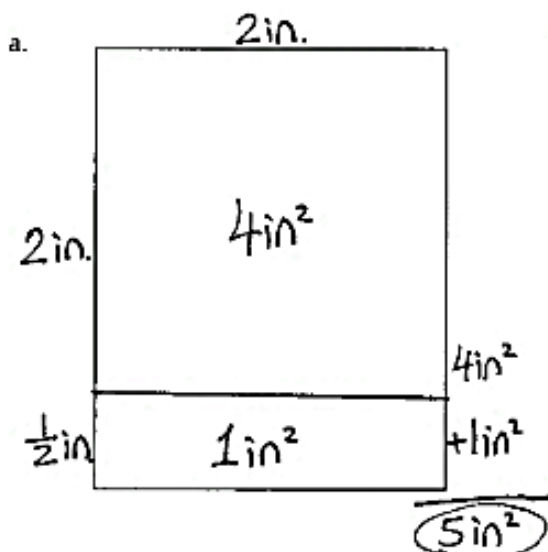

Lesson 13

Objective: Multiply mixed number factors, and relate to the distributive property and the area model.

Find the area of the following rectangles. Draw an area model if it helps you.

a. $\frac{5}{4} \text{ km} \times \frac{12}{5} \text{ km}$

$$= \frac{5}{4} \times \frac{12}{5}$$

$$= \frac{\cancel{5} \times 12}{\cancel{4} \times \cancel{5}}$$

$$= 3 \text{ km}^2$$

b. $16\frac{1}{2} \text{ m} \times 4\frac{1}{5} \text{ m}$

$$= \frac{33}{2} \times \frac{21}{5}$$

$$= \frac{693}{10}$$

$$= 69\frac{3}{10} \text{ m}^2$$

Lesson 14

Objective: Solve real world problems involving area of figures with fractional side lengths using visual models and/or equations.

1. George decided to paint a wall with two windows. Both windows are $3\frac{1}{2}$ ft by $4\frac{1}{2}$ ft rectangles. Find the area the paint needs to cover.

Area of window $3\frac{1}{2} \times 4\frac{1}{2} = \frac{7}{2} \times \frac{9}{2} = \frac{63}{4} = 15\frac{3}{4} \text{ ft}^2$ $12\frac{7}{8} \text{ ft}$

2 windows: $15\frac{3}{4} \times 2 = 30\frac{6}{4} = 31\frac{1}{2} \text{ ft}^2$

Area of wall: $12\frac{7}{8} \times 8 = 96 + 7 = 103 \text{ ft}^2$

Area to paint: $103 - 31\frac{1}{2} = 71\frac{1}{2} \text{ ft}^2$

The paint needs to cover $71\frac{1}{2} \text{ ft}^2$.

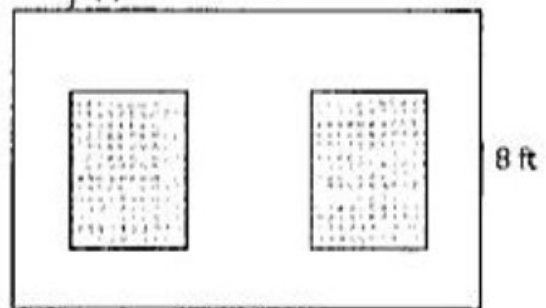

Lesson 15—Objective: Solve real world problems involving area of figures with fractional side lengths using visual models and/or equations.

- Mrs. Johnson's grows herbs in square plots. Her basil plot measures $\frac{5}{8}$ yd on each side.
 - Find the total area of the basil plot.

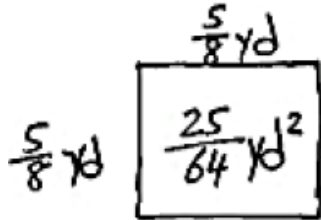

The total area of the basil plot is $\frac{25}{64}$ yd².

- Mrs. Johnson puts a fence around the basil. If the fence is 2 ft from the edge of the garden on each side, what is the perimeter of the fence?

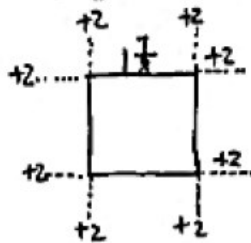

$$\begin{aligned} \frac{5}{8} \text{ yd} &= \frac{5}{8} \times 1 \text{ yd} \\ &= \frac{5}{8} \times 3 \text{ ft} \\ &= \frac{15}{8} \text{ ft} \\ &= 1\frac{7}{8} \text{ ft} \end{aligned}$$

$$1\frac{7}{8} \text{ ft} + 4 \text{ ft} = 5\frac{7}{8} \text{ ft}$$

$$\begin{aligned} 5\frac{7}{8} \text{ ft} \times 4 \\ = 20\frac{28}{8} \text{ ft} \end{aligned}$$

$$= 23\frac{1}{2} \text{ ft}$$

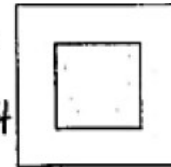

Lesson 16

Objective: Draw trapezoids to clarify their attributes, and define trapezoids based on those attributes.

- Draw a pair of parallel lines in each box. Then use the parallel lines to draw a trapezoid with the following:

<p>No right angles.</p> <p>Hand-drawn trapezoid with angles 107°, 100°, 73°, and 80°.</p>	<p>Only 1 obtuse angle.</p> <p>Hand-drawn trapezoid with angles 90°, 90°, 115°, and 65°.</p>
---	--

Lesson 17

Objective: Draw parallelograms to clarify their attributes, and define parallelograms based on those attributes.

Draw a parallelogram in each box with the attributes listed.

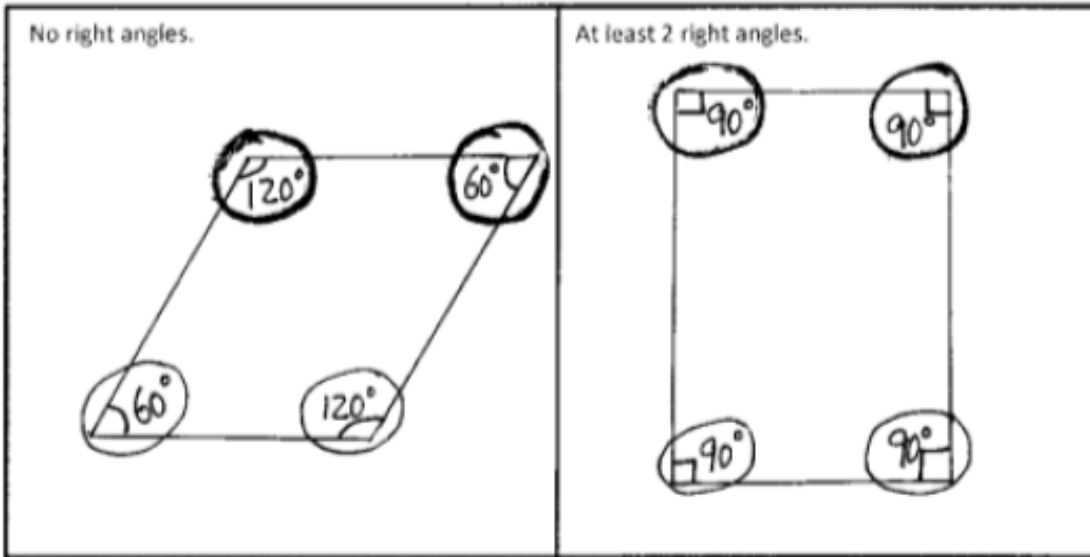

Lesson 18

Objective: Draw rectangles and rhombuses to clarify their attributes, and define rectangles and rhombuses based on those attributes.

Draw the figures in each box with the attributes listed.

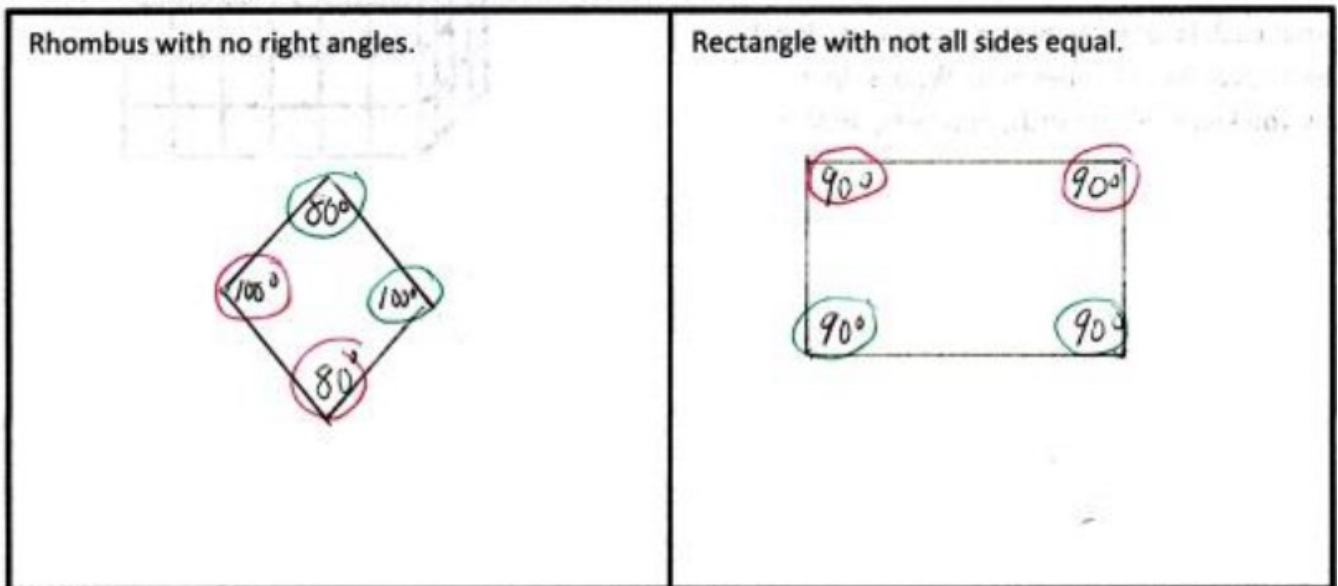

Lesson 19

Objective: Draw kites and squares to clarify their attributes, and define kites and squares based on those attributes.

1. Draw the figures in each box with the attributes listed. If your figure has more than one name, write it in the box.

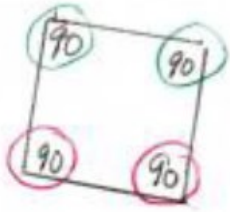
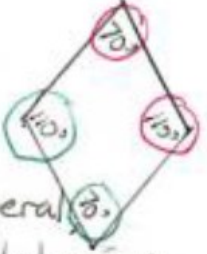
<p>Rhombus with 2 right angles.</p>  <p>Rhombus, rectangle, square, parallelogram, trapezoid, quadrilateral</p>	<p>Kite with all sides equal.</p>  <p>Kite, quadrilateral, rhombus, parallelogram, trapezoid</p>
--	---

Lesson 20—Objective: Classify two-dimensional figures in a hierarchy based on properties.

True-False. If the statement is false, rewrite it to make it true.

	T	F
a. All trapezoids are quadrilaterals.	✓	
b. All parallelograms are rhombuses. Some parallelograms are rhombuses.		✓
c. All squares are trapezoids.	✓	
d. All rectangles are squares. All squares are rectangles.		✓
e. Rectangles are always parallelograms.	✓	
f. All parallelograms are trapezoids.	✓	
g. All rhombuses are rectangles. Some rhombuses are rectangles.		✓
h. Kites are never rhombuses. Kites are sometimes rhombuses.		✓

Lesson 21

Objective: Draw and identify varied two-dimensional figures from given attributes.

John says that because rhombuses don't have perpendicular sides, they can't be rectangles. Explain his error in thinking.

Some rhombuses do have perpendicular sides.
These are squares, and squares are rectangles.

Jack says that because kites don't have parallel sides, a square isn't a kite. Explain his error in thinking.

A kite just has 2 pairs of equal adjacent sides, so a square is a kind of kite since it has 2 pairs of equal adjacent sides. So a square is a kind of kite.